

# AT-100, Direct Drive Rotary Air Bearing Stage

## Ultra-Precision Rotary Axis

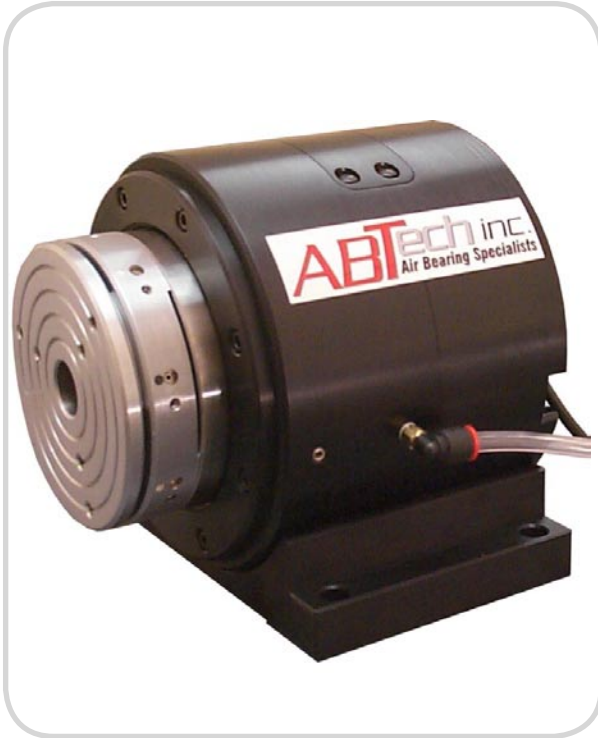

ABTech's model AT-100 air bearing rotary stage provides zero non-repeat error motion combined with a "High Torque", brushless DC servo motor for ultra-smooth and precise rotary motion.

The air bearing spindle is constructed of hardened stainless steel for durability and long life, providing added value over conventional aluminum spindles.

The spindle motor is designed to accommodate a wide range of precision motion applications such as ultra precision scanning, velocity control, speed regulation and precision indexing with angular step accuracies to  $\pm 0.0005^\circ$  available. Indexing cycles can be variable and range in example from a  $0.1^\circ$  per a 20/30sec move window to a rapid  $180^\circ/\text{sec}$  to  $360^\circ/\text{sec}$  bi-directional index depending on the encoder resolution and control provided.

ABTech's modular design approach facilitates six levels of system packaging to optimize the price for performance required in your application.

Some typical applications:

Ultra-smooth scanning, Precision velocity & speed control, Sample indexing for image acquisition systems (Goniostat Omega axis), Micro-machining, Optical metrology and circular geometry gages (reference axis).

## Features

- "Zero" static friction
- Ultra-smooth motion with absolute
- repeatability
- Radial/axial error motion:  $0.125\mu\text{m}$  ( $5.0\mu\text{m}$ ) \*
- Variable speed control
- Rapid bi-directional indexing, up to  $360^\circ/\text{sec}$  \*\*
- Angular step accuracy:  $\pm 0.0005^\circ$  \*\*
- High load capacity and stiffness
- High torque, cogless brushless DC motor
- Non-contact drive (no drive train parts to wear)
- Sinusoidal or trapezoidal commutation
- Durable 440C stainless steel construction

Additional sizes, AT-150 & AT-200



AT - 200 Direct Drive Air Bearing w/ Vertical axis base mounting.

\* = Additional error motion specifications available.

\*\* = Encoder resolution & control dependent

# Specifications

## AT-100 w/Direct Drive (Axis in horizontal configuration)

FOR DETAILED CAD DRAWING,  
CONTACT ABTECH DIRECTLY.

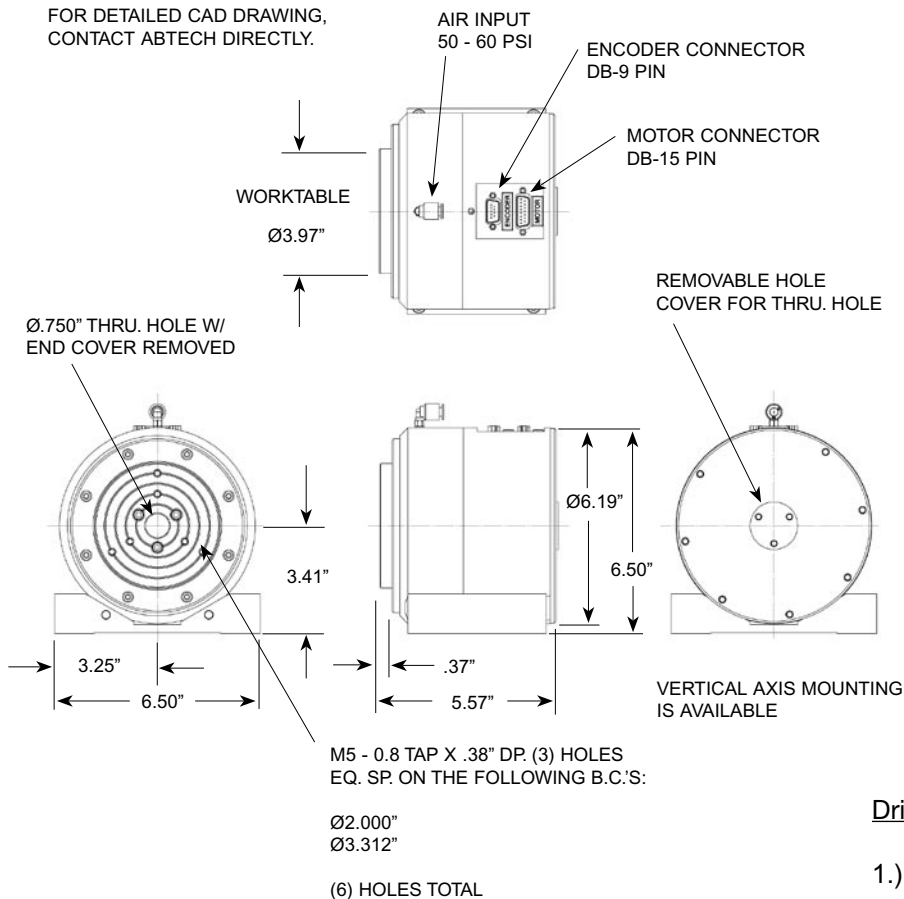

## Performance

Radial / axial error motion: 5.0 $\mu$ " (0.125 $\mu$ m)  
 Angular error motion: 1.0 $\mu$ "/in. (0.025 $\mu$ m/25mm)  
 Axial load capacity: 125lbs (57Kg)  
 Axial Stiffness: 0.6lbs/ $\mu$ " (10.8kgf/ $\mu$ m)  
 Air consumption: 1.0scfm (1.7m $\Delta$ /h)  
 Air supply: 60psi (4.14bar)  
 Motor: Brushless DC (Frameless)  
 Encoder: Renishaw RESR rotary ring, Ø115mm  
 Encoder resolution: 0.1 $\mu$ m (0.0001°) standard  
 0.05 $\mu$ m (0.00005°) available  
 Angular step accuracy:  $\pm$ 0.0005° standard  
 $\pm$ 0.0002° available  
 Rotational Speed: 360°/sec. w / 0.1 $\mu$ m res. encoder  
 180°/sec. w / 0.05 $\mu$ m res. encoder  
 Interpolation clock rate of: 12MHz/Min.

## Accessories/Options

- Motion controls - see below
- Tilt/center worktables
- Special mounting flanges
- Vacuum thru. to worktable
- Granite surface plates & support
- Air filter/regulator units
- Custom tooling

## Drive Package Options: (prices change w/option)

- 1.) Spindle w/ encoder (sel. res.) & motor only.
- 2.) Spindle, encoder, motor & simple drive amplifier (PWM or Linear) Must provide us with motion control data to interface with.
- 3.) Spindle w/encoder, motor & programmable digital drive amplifier (PWM or Linear) Must provide us with motion control data to interface with.
- 4.) Spindle, w/encoder, motor, simple drive amplifier and multi-axis controller. (Additional details are required for multi-axis controller. Axis configuration and type of motion controller will effect pricing).
- 5.) Spindle, w/encoder, motor, programmable digital drive amplifier and multi-axis controller. (Additional details are required for multi-axis controller. Axis configuration and type of motion controller will effect pricing).
- 6.) Option 4 & 5 with operator interfaces (Additional details required - consult ABTech, Inc.

AT100-M100V Direct Drive			
Table Size *	Ø4.00" (100mm)	Max. Rated Torque	975oz in. (6.88Nm)
Axial Load	125lb. (57Kg) Balanced	Max. Cont. Stall Torque	168oz in. (1.19Nm)
Axial Stiffness	0.6lbs/ $\mu$ " (10.8Kgf/ $\mu$ m)	Peak Torque	609oz in. (4.30Nm)
Motor	DC Brushless Servo	Torque Sensitivity	44.6oz in./amp (0.31Nm/amp)
		Motor Constant	33.7oz in./sqrt (w) 0.24Nm/sqrt (w)

\* = Additional sizes available, consult ABTech, Inc.  
 Load & stiffness are specified at 60psi.  
 Table operating pressure range is from 30psi to 70psi  
 Specifications are subject to change without notification

Tel: 603-358-6431  
 Fax: 603-358-0196

**ABTech inc.**  
 Pride In Precision

On Line: [www.abtechmfg.com](http://www.abtechmfg.com)